

AR-6

6 METER RINGO



951285 (7/93)

TA5FA

WARNING

THIS ANTENNA IS AN ELECTRICAL CONDUCTOR. CONTACT WITH POWER LINES CAN RESULT IN DEATH, OR SERIOUS INJURY. DO NOT INSTALL THIS ANTENNA WHERE THERE IS ANY POSSIBILITY OF CONTACT WITH OR HIGH VOLTAGE ARC-OVER FROM POWER CABLES OR SERVICE DROPS TO BUILDINGS. THE ANTENNA, SUPPORTING MAST AND/OR TOWER MUST NOT BE CLOSE TO ANY POWER LINES DURING INSTALLATION, REMOVAL OR IN THE EVENT PART OF THE SYSTEM SHOULD ACCIDENTALLY FALL. FOLLOW THE GUIDELINES FOR ANTENNA INSTALLATIONS RECOMMENDED BY THE U.S. CONSUMER PRODUCT SAFETY COMMISSION AND LISTED IN THE ENCLOSED PAMPHLET.

Your Cushcraft AR-6 vertical antenna is designed and manufactured to give trouble free service. This antenna will perform as specified if the instructions and suggestions in this manual are followed and care is used in the assembly and installation. When checking the components received in your antenna package use the parts listed beside each diagram. There is a master parts list on page 2. *IMPORTANT: Save the weight label from the outside of the carton. Each antenna is weighed at the factory to verify the parts count. If you claim a missing part, you will be asked for the weight verification label.*

PLANNING

Plan your installation carefully. If you use volunteer helpers be sure that they are qualified to assist you. Make certain that everyone involved understands that you are in charge and that they must follow your instructions. If you have any doubts at all, employ a professional antenna installation company to install your antenna.

LOCATION

Location of the antenna is very important. Surrounding objects such as buildings, trees, powerlines, towers, other antennas, etc. will seriously reduce efficiency. To minimize the effects of surrounding objects, mount the antenna as high and in the clear as possible. If metal guy wires are used, they should be broken with strain insulators.

EXTREME CARE MUST BE USED FOR YOUR SAFETY. YOU MUST INSURE THAT WHILE THE AR-6 IS IN OPERATION NEITHER PEOPLE OR PETS CAN COME IN CONTACT WITH ANY PORTION OF YOUR ANTENNA INCLUDING THE GROUND RADIALS. DEADLY VOLTAGES AND CURRENTS MAY EXIST. ALSO, SINCE THE EFFECTS OF EXPOSURE TO RF ARE NOT FULLY UNDERSTOOD, LONG TERM EXPOSURE TO INTENSE RF FIELDS IS NOT RECOMMENDED. THERE IS A WARNING STICKER PROVIDED THAT IS TO BE ATTACHED TO THE BASE OF THE AR-6.

MOUNTING

The AR-6 will take a 1" (2.5 cm) to 1-1/4" (3.2 cm) OD mast. For all installations the antenna must be mounted on the top 6 inches (15 cm) of a mast. It should be mounted above horizontally polarized beam antennas. If you side mount this antenna on a tower it will require a short mast, secured at two points. The mast should be kept at least 1/2 wavelength or 40 inches (100 cm) away from the tower.

SYSTEM GROUNDING

Direct grounding of the antenna mast is very important. This serves as protection from lightning strikes and static buildup, and from high voltages which may be present in the equipment attached to the antenna. A good electrical connection should be made to one or more ground rods directly at the base of the antenna using a least #10 AWG ground wire and non-corrosive hardware. For details and safety standards, consult the National Electrical Code. You should also use a coaxial lightning arrestor. Cushcraft offers several different models, such as the LAC-1, LAC-2 or the LAC-4 series.

ASSEMBLY

Assemble your AR-6 by following steps 1 through 4. After assembling the antenna, verify all dimensions for accuracy and then return to the tuning section below for final adjustment.

TUNING

Use a good quality 50 Ohm coaxial cable with PL-259 connector. Run the cable from your transmitter to the area in which the antenna is going to be tested. The length of this cable or your feedline is not critical. Connect a short length of cable [10 ft. (3m) or less] from the VSWR bridge to the antenna. Set the transmitter to your center operating frequency. When you read VSWR, be sure to move far enough away from the antenna so that your body does not affect the reading.

After dimensions A and B have been set according to Chart 1, the initial tune-up may be done at ground level clear of metallic objects. Adjust the transmitter and bridge for maximum forward power. Check the VSWR (reflected power with the bridge in the reverse position). If the VSWR is high, loosen the tuning rod clamp and adjust the rod slightly in either direction. If the VSWR increased, move the rod back to its original position and adjust in the opposite direction. If the SWR dropped, repeat adjustment until there is little or no reflected power indicated on the bridge and you will have matched your antenna to 50 Ohms. Tape feedline to the boom.

MASTER PARTS LIST

| KEY | PART # | DESCRIPTION | QTY | KEY | PART # | DESCRIPTION | QTY |
|-----|--------|--|-----|-----|--------|---|-----|
| 9 | 010009 | 8-32 x 5/8" (1.6 cm) stainless steel machine screw | 1 | 326 | 290326 | Danger label | 1 |
| 11 | 010011 | 8-32 stainless steel hex nut | 5 | 370 | 250370 | Adhesive epoxy pack | 1 |
| 12 | 050012 | 3/4" black plastic cap | 1 | 409 | 030409 | 7/8" stainless steel worm clamp | 1 |
| 22 | 053622 | 3/8" (.95 cm) white plastic cap | 1 | 410 | 030410 | 1" (2.54 cm) stainless steel worm clamp | 1 |
| 41 | 011941 | #8 stainless steel split lock washer | 4 | 941 | 360941 | 1/4" (.6 cm) stainless steel flat washer | 3 |
| 65 | 012965 | 1/4"-20 (.6 cm) stainless steel lock nut | 1 | BA | | Base assembly | 1 |
| 70 | 082070 | 7/16" (1.1 cm) aluminum tuning rod | 1 | BB | | 7/8" x 44" (2.2 x 112 cm) aluminum tube slotted one end | 1 |
| 81 | 010081 | 1/4"- 20 x 3/4" (.6 cm-20 x 1.9 cm) s.s. machine screw | 1 | BC | | 3/4" x 40" (1.9 x 102 cm) aluminum tube | 1 |
| 93 | 200093 | Tuning rod clamp | 1 | RS | | 3/8" (.9 cm) aluminum ring sections | 2 |
| 96 | 010096 | 8-32 x 3/8" (1.6 cm) stainless steel machine screw | 3 | TS | | 7" (18 cm) RG.6U coaxial tuning stub | 1 |
| 115 | 050115 | Vinyl connector boot | 1 | | | | |
| 116 | 240116 | Silicone grease packet | 1 | | | | |

#1 - ASSEMBLE TUNING RING

Mount one half ring (RS) to the bottom side of the lower bracket on the base assembly (BA) using hardware shown in Figure 1. Mount the other half ring to the top of the upper bracket. Connect the two half rings to form a circle around the base assembly.

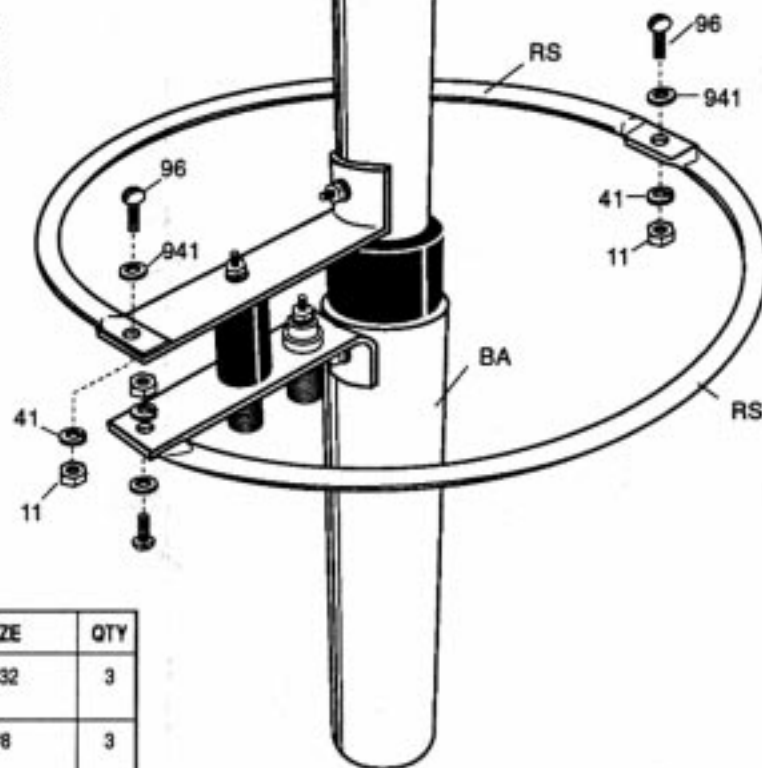



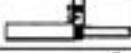



FIGURE 1

| KEY | PART # | | DESCRIPTION | SIZE | QTY |
|-----|--------|---|-----------------------------------|---------------------|-----|
| 11 | 010011 |  | Stainless Steel Hex Nut | 8-32 | 3 |
| 41 | 011941 |  | Stainless Steel Split Lock Washer | #8 | 3 |
| 96 | 010096 |  | Stainless Steel Machine Screw | 8-32 x 3/8" (.9 cm) | 3 |
| 941 | 360941 |  | Stainless Steel Flat Washer | 1/4" (.6 cm) | 3 |
| BA | |  | Base Assembly | | 1 |
| RS | |  | Ring Sections | | 2 |

#2 - ASSEMBLE BASE

Assemble the tuning rod clamp (93) using machine screw (9) and hex nut (11) per figure 2-A. Slide the clamp over the ring section and the tuning rod through the hole in the clamp. Attach the flattened end of the tuning rod to the top of the coax fitting with a lock washer (41) and nut (11) per figure 2-B. The exact position of the tuning rod will be determined during the tuning procedure after assembly.

Look at Chart 1 for the frequency you will be operating at and find the corresponding "B" dimension. Referring to figure 2-C, make the necessary modification to the tuning stub. A plastic cap (22) has been provided to weatherproof the tuning stub. Included with the antenna is a packet of epoxy. Follow the mixing directions on the packet and apply some to the stripped end of the tuning stub. Slide the clear plastic cap onto the end of the tuning stub as far as it will go.

Attach mastng screw (81) and nut (65) per figure 2-C. Affix danger label (326) to the base (figure 2).

CHART 1

| Freq. MHz | Dimension A | | Dimension B | |
|--------------|----------------|---------|----------------|---------|
| | Inches | CM | Inches | CM |
| 49.0 | 114 | (289.6) | 4-5/8 | (11.75) |
| 50.0 | 112 | (284.5) | 4-1/4 | (10.8) |
| 51.0 | 110 | (279.4) | 3-7/8 | (9.8) |
| 52.0 | 108 | (274.3) | 3-1/2 | (8.9) |
| 53.0 | 106 | (269.2) | 3-1/8 | (7.9) |
| 54.0 | 104 | (264.2) | 2-3/4 | (7.0) |



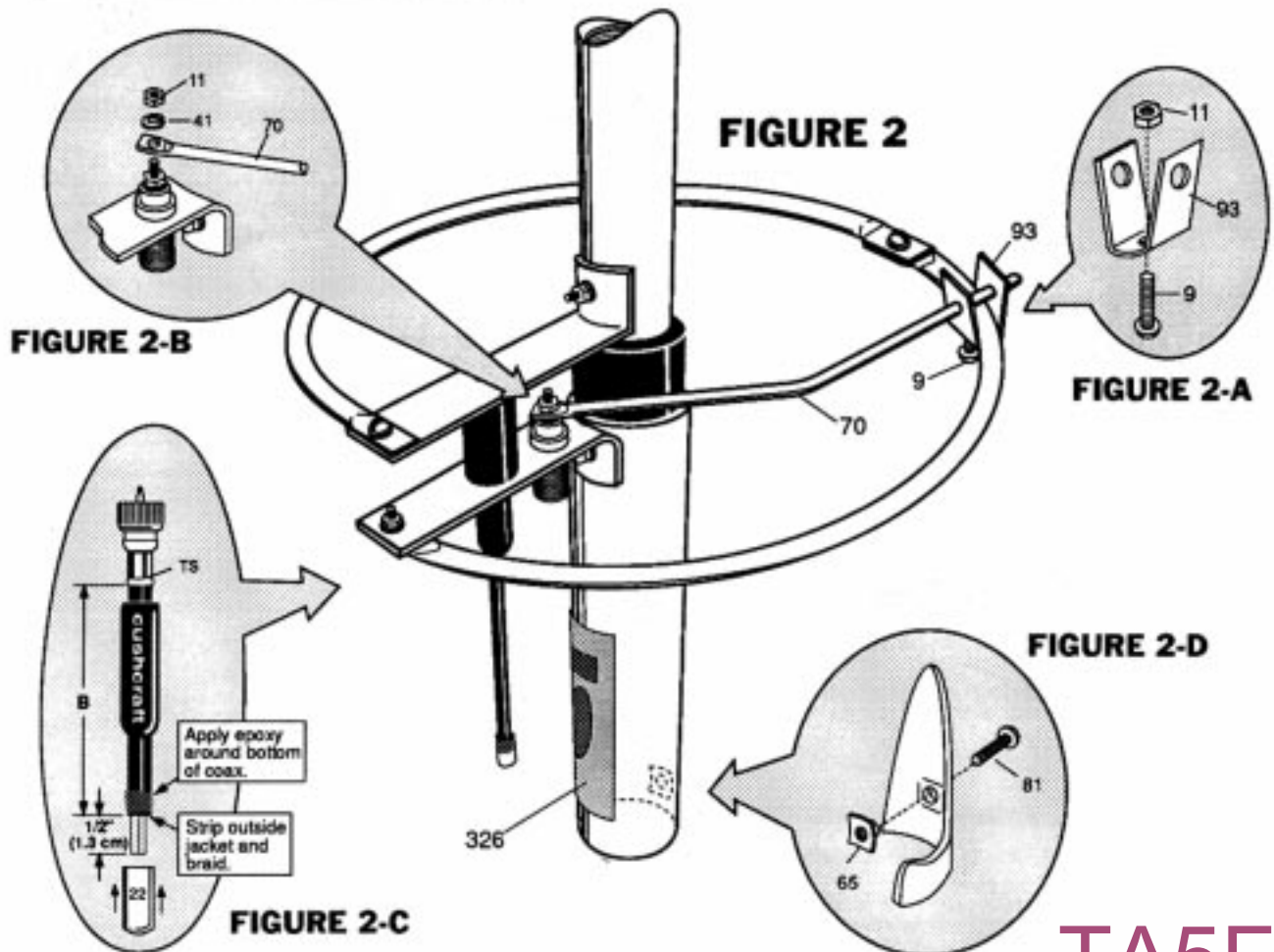

| KEY | PART # | | DESCRIPTION | SIZE | QTY |
|-----|--------|---|---------------------------------|-----------------------------------|-----|
| 9 | 010009 |  | Stainless Steel Machine Screw | 8-32 x 5/8" (1.6 cm) | 1 |
| 11 | 010011 |  | Stainless Steel Hex Nut | 8-32 | 2 |
| 22 | 053622 |  | White Plastic Cap | 3/8" (.96 cm) | 1 |
| 41 | 011041 |  | Stainless St. Split Lock Washer | #8 | 1 |
| 65 | 012965 |  | Stainless Steel Lock Nut | 1/4"-20 (.6 cm) | 1 |
| 70 | 082070 |  | Aluminum Tuning Rod | 7/16" (1.1 cm) | 1 |
| 81 | 010081 |  | Stainless Steel Machine Screw | 1/4"-20 x 3/4" .6-20 x 1.9 cm) | 1 |
| 93 | 200093 |  | Tuning Rod Clamp | | 1 |
| 326 | 290326 |  | Danger Label | | 1 |
| 370 | 250370 |  | Epoxy Pack | | 1 |
| TS | |  | Coaxial Tuning Stub | 7" (18 cm) | 1 |



TA5FA

#3 - ASSEMBLE RADIATOR

Place the 1" worm clamp (410) over the slotted end of the base assembly. Insert the non-slotted end of tube BB X inches (cm) into the base section and tighten the worm clamp. Place the 7/8" worm clamp (409) over the slotted end of BB. Insert the non-slotted end of BC into BB until you have achieved dimension A (Chart 1). Tighten clamp (409) and place cap (12) on the top of the radiator.

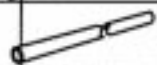
| KEY | PN | | DESC. | SIZE | QTY |
|-----|--------|---|----------------------------|------------------------------|-----|
| 12 | 050012 |  | Black Plastic Cap | 3/4" (1.9 cm) | 1 |
| 409 | 030409 |  | Stainless Steel Worm Clamp | 7/8" (2.2 cm) | 1 |
| 410 | 030410 |  | Stainless Steel Worm Clamp | 1" (2.5 cm) | 1 |
| BB | |  | Aluminum Tube | 7/8" x 44" (2.2 x 112 cm) | 1 |
| BC | |  | Aluminum Tube | 3/4" x 40" (1.9 x 102 cm) | 1 |

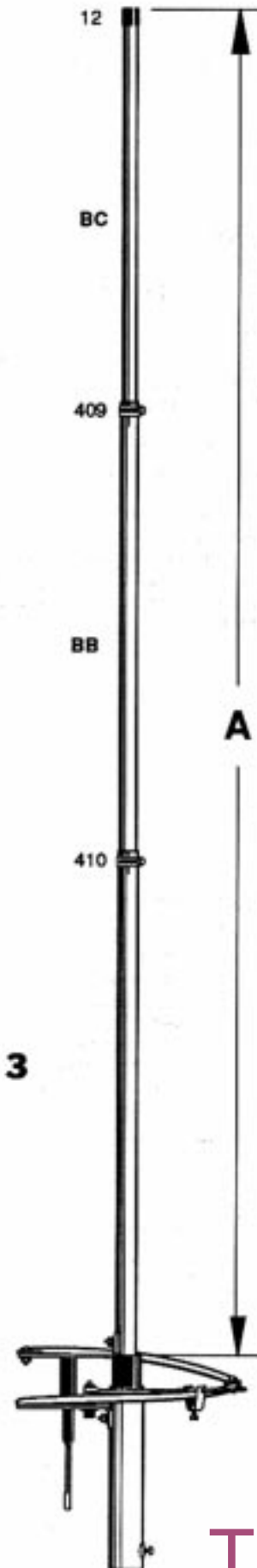

FIGURE 3

TA5FA

#4 - MOUNT ON MAST

The AR-6 can be mounted on a mast with an outside diameter of 1" to 1-1/4" (2.5-3.2 cm). Slide the antenna over the mast as far as it will go and secure by tightening locking screw (figure 4).

#5 - FEEDLINE

The AR-6 is designed for use with 50 Ohm coaxial cable terminated with a PL-259 connector. Any length of cable can be used with your AR-6. The shortest length of cable will have the least loss. A connector boot is included for use with your new antenna (figure 4). Slide the boot over the cable before attaching your PL-259. Coat only the outside connector threads and shell with silicone grease. Do not coat the center pin or receptacle. After the PL-259 is firmly screwed onto the antenna connector, slide the vinyl boot over the connector and against the connector bracket for a good weather-tight connection. After the antenna is on the mast, tape the feedline to the mast. If you plan to install the antenna in a salty or corrosive environment, you may want to consider coating it with a clear marine varnish or equivalent after it is assembled. For final tuning see page 1.

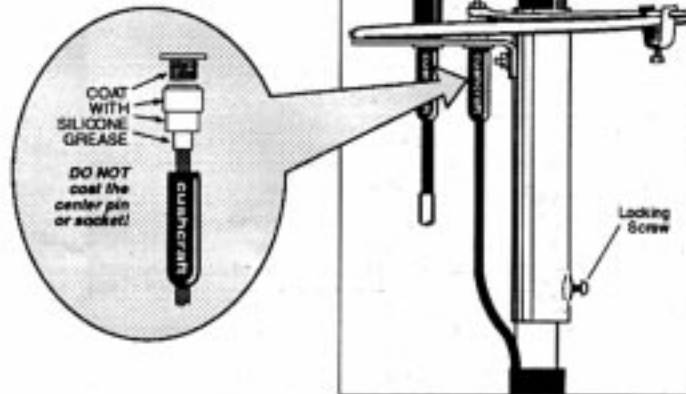

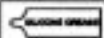

FIGURE 4

| KEY | PN | | DESC. | SIZE | QTY |
|-----|--------|---|------------------|------|-----|
| 115 | 050115 |  | Connector Boot | | 1 |
| 116 | 050116 |  | Silicone Package | | 1 |

SPECIFICATIONS

| | | | |
|---------------------------------------|-------|--|------------------|
| Model | AR-6 | | |
| Frequency, MHz | 50-54 | Base Diameter, in (cm) | 1 (2.5) |
| 2:1 Bandwidth in MHz | 2 | | |
| Gain, dB | 3.75 | Height, ft (m) | 10.1 (3.1) |
| Power Rating, Watts FM | 1000 | Mast Size Range, in (cm) | 1-1.25 (2.5-3.1) |
| Radiation Pattern, Degrees | 16 | Wind Load, ft ² (m ²) | 0.37 (0.03) |
| Horizontal Radiation Pattern, Degrees | 360 | Weight, lb (kg) | 2.5 (1.1) |

LIMITED WARRANTY

Cushcraft Corporation, P.O. Box 4680, Manchester, New Hampshire 03108, warrants to the original consumer purchaser for one year from date of purchase that each Cushcraft antenna is free of defects in material or workmanship. If, in the judgement of Cushcraft, any such antenna is defective, then Cushcraft Corporation will, at its option, repair or replace the antenna at its expense within thirty days of the date the antenna is returned (at purchaser's expense) to Cushcraft or one of its authorized representatives. This warranty is in lieu of all other expressed warranties, any implied warranty is limited in duration to one year. Cushcraft Corporation shall not be liable for any incidental or consequential damages which may result from a defect. Some states do not allow limitations on how long an implied warranty lasts or exclusions or limitations of incidental or consequential damages, so the above limitation and exclusion may not apply to you. This warranty gives you specific legal rights, and you may also have other rights which vary from state to state. This warranty does not extend to any products which have been subject to misuse, neglect, accident or improper installation. Any repairs or alterations outside of the Cushcraft factory will nullify this warranty.



48 PERIMETER ROAD, MANCHESTER, NH 03108 • 603-627-7877 / TELEX 4949472 / FAX 603-627-1764

SPECIFICATIONS SUBJECT TO CHANGE WITHOUT NOTICE

TA5FA